

HELI

**CPD 15/16
/18/20
GE2DLI**



LIION 1.5-2 t

**G3 series Dual Drive Lithium-ion
Battery Forklift Truck**

HELI



GREAT ENERGY





SMALL BODY, --- GREAT ENERGY



High performance ensures high efficiency

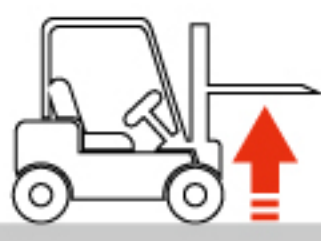

Front wheel with dual drive motor provides more power

 <p>17-18km/h Driving speed</p>	 <p>20% Maximum climbable gradient at full load</p>
 <p>0.46m/s Maximum lifting speed with load</p>	 <p>0.65m/s Maximum lifting speed at full load load</p>
 <p>Strong carrying capacity on high</p>	

Multiple configuration, Low energy consumption



Steering according to the demand of oil, reduce the energy consumption of the vehicle



High precision angle potentiometer makes steering more sensitive and accurate.



The forklift truck is equipped with high brightness, long life, more energy saving LED lights.

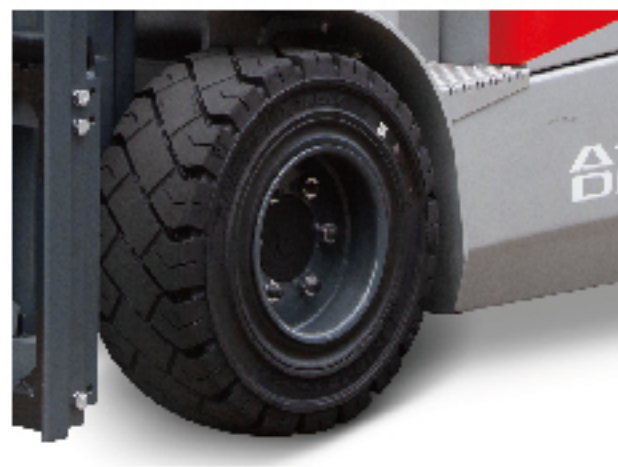

Low rolling resistance electric truck special solid tire reduces driving resistance consumption.

Small dimension, More flexible

European small vehicle width is suitable for narrow aisle passage. Large angle steering axle makes the turning radius smaller satisfying the loading and unloading operation in narrow aisle.



The minimum turning radius is as low as **1.74m**

Quick charge, long battery life

- Realizes faster charging; standard 202ah lithium battery has ultra long endurance;
- The characteristics of high-density energy and quick charging of lithium battery make all day uninterrupted operation of a forklift truck.

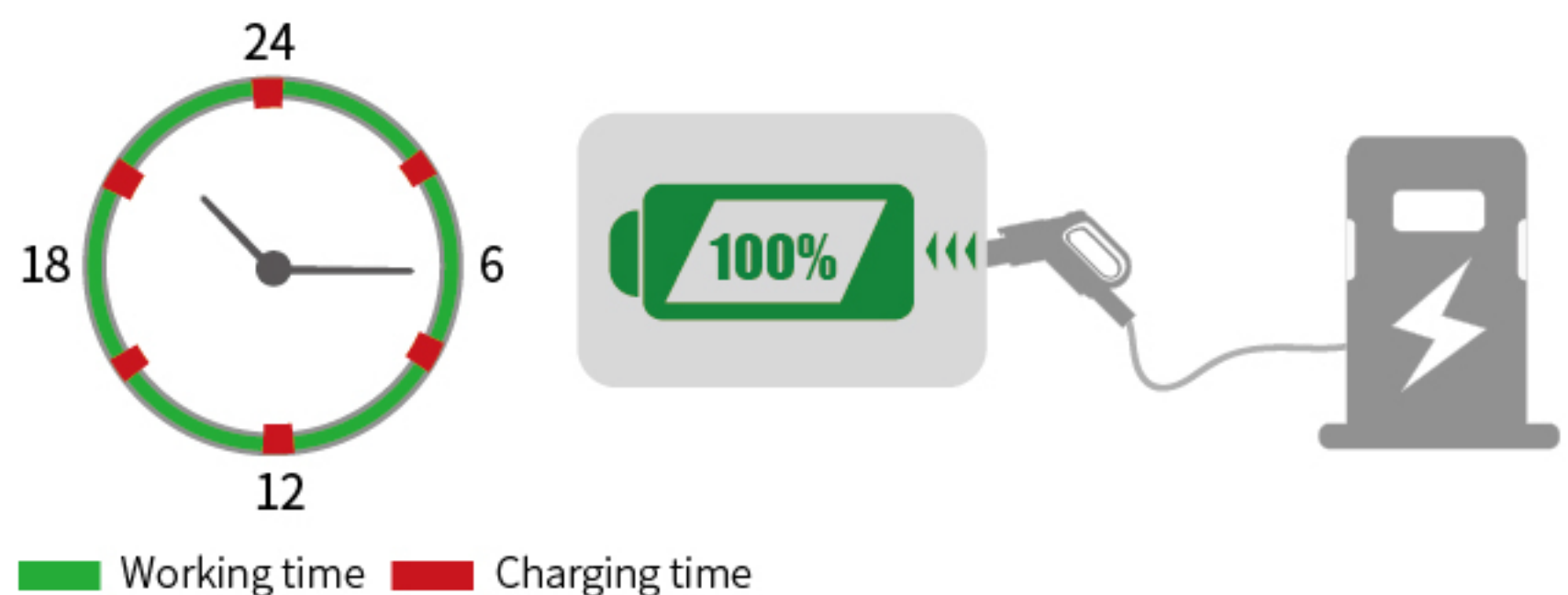

Enjoy driving experience

Alphanumeric display Battery discharge indicator



- Keyboard button: Enter
- Hour meter
- Keyboard button: Roll up
- Fallure alarm LED
- Low battery LED
- Keyboard button: Roll down
- Battery discharge indicator
- Exit button
- Seat switch LED
- Handbrake status
- Keyboard button: Set down
- Oil temperature alarm (no use)
- Keyboard button: Set up

ZAPI Display



- P — Powerful
 - E — Economical
 - S — Energy Saving
- Multiple performance modes could meet the needs of various working conditions.



Center rearview mirror



New pedal parking system, ergonomic design, very convenient



USB power supply



Storage box



The mast with large opening offers good driving vision ensuring operation comfort and safety.



Large space to get on, and large leg space, more comfortable operation

Intelligent security protection

- Intelligent induction of mast taking off and landing** can avoid limit impact, and it is safe and comfortable;
- Intelligent speed limit in different application:** multi application recognition and intelligent speed limit balance efficiency and safety;
- Intelligent limit buffer:** intelligent induction of mast lifting and lowering avoids limit impact and is safe and comfortable;
- Intelligent operation protection:** a full set of OPS system can avoid misoperation and ensure safety;
- Intelligent control strategy:** dual core controller is in line with the latest EU safety requirements.
- Intelligent steering deceleration:** the automatic deceleration function of the turning can reduce the risk of turning over;
- Lithium batteries heat themselves automatically at low temperatures,** and their adaptation performances are superior.

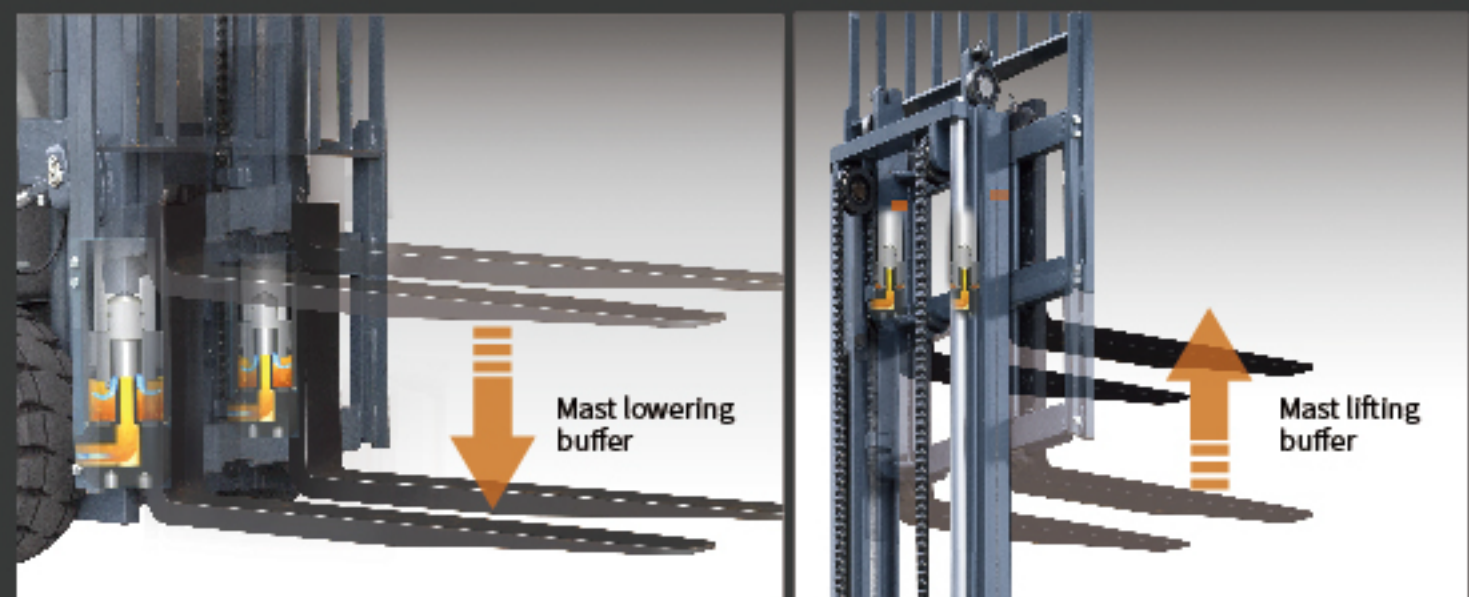
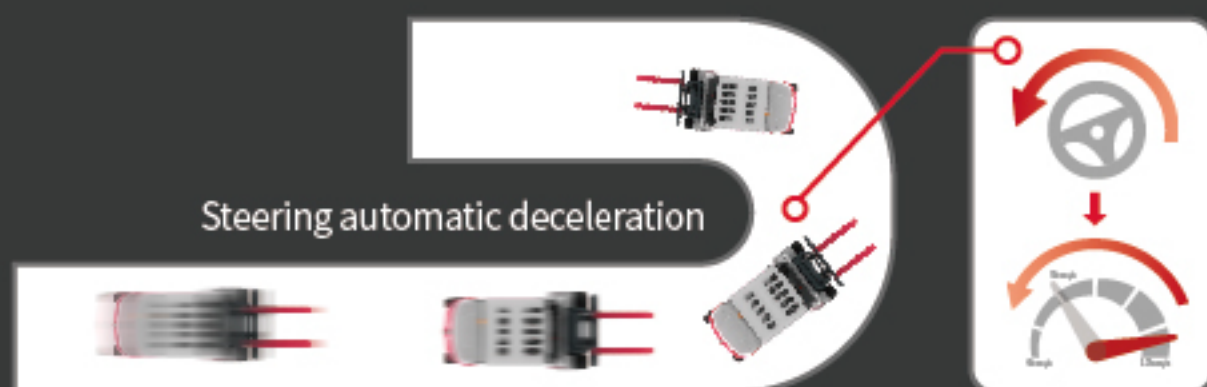
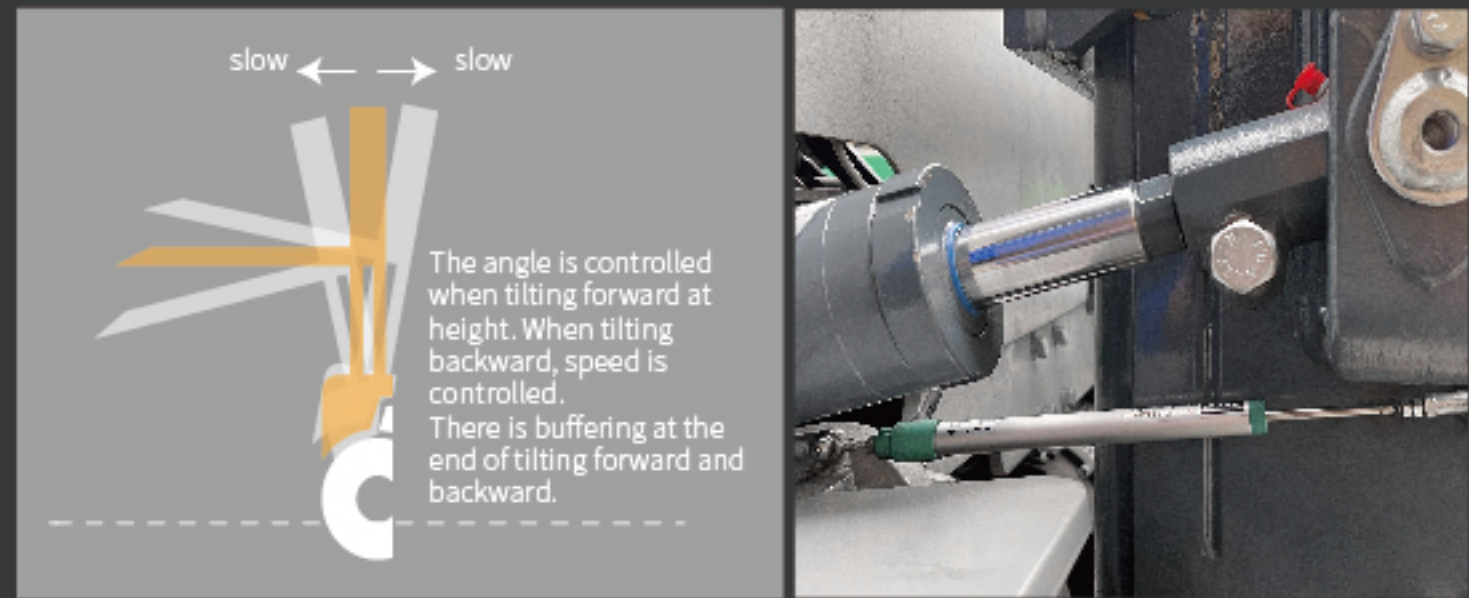

Operating Cost Comparison:

Lithium battery forklift **vs.** Lead-acid battery forklift **vs.** IC forklift

The advantages of HELI lithium battery forklift trucks are more prominent in the life cycle cost. Compared with internal combustion forklift truck, lithium battery forklift truck has the advantages of no noise, no pollution, small vibration and simple operation. Compared with the lead-acid battery forklift truck, lithium battery forklift has the characteristics of fast charging and charging at any time, which is more suitable for multi shift operation. Besides, HELI Lithium-ion Battery Forklift is maintenance-free, with high energy conversion, saving a lot of operating costs.

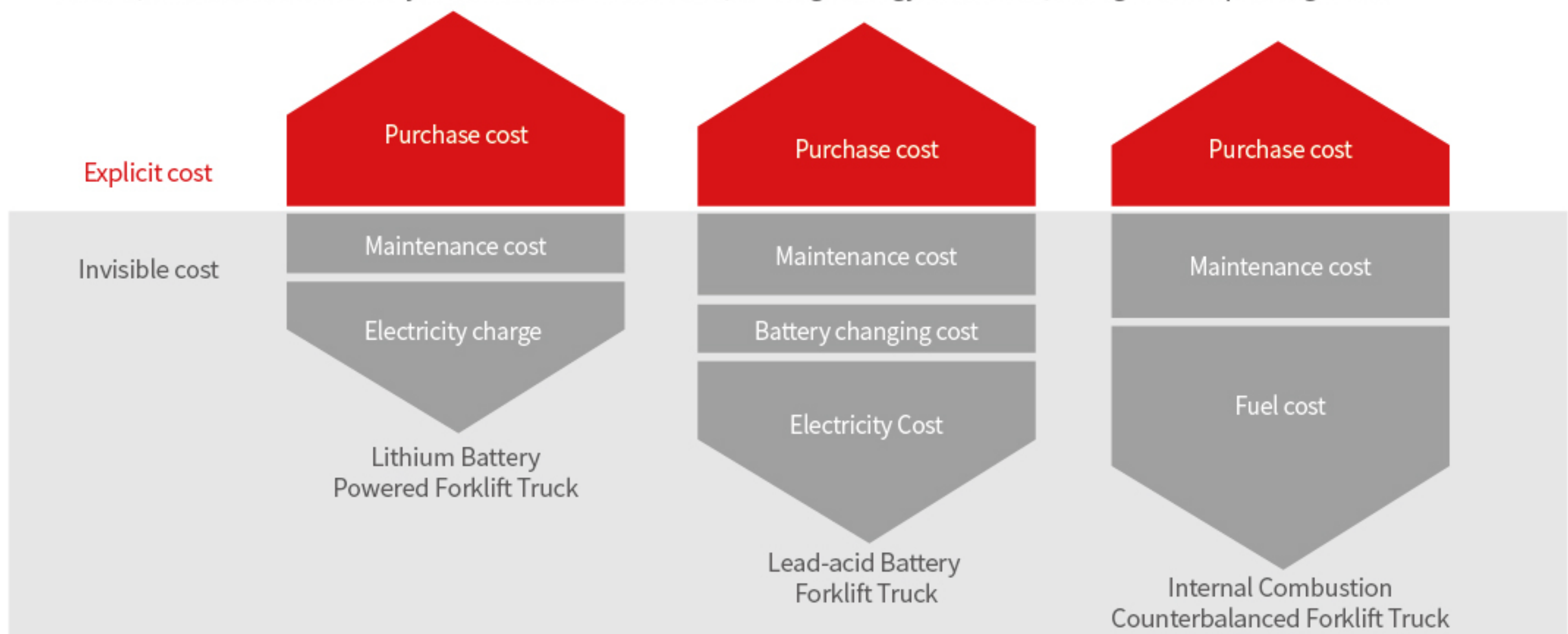

Reliable Quality, Easy Maintenance

The whole vehicle works alternately in the -20°C cold storage and is parked in the cold storage for 12 hours.
 The whole vehicle is trouble-free and can run sustainably.
 The reinforced casting steering axle is mature and reliable. The force optimization design of mast improves the overall performance and ensure the safety of operation effectively.

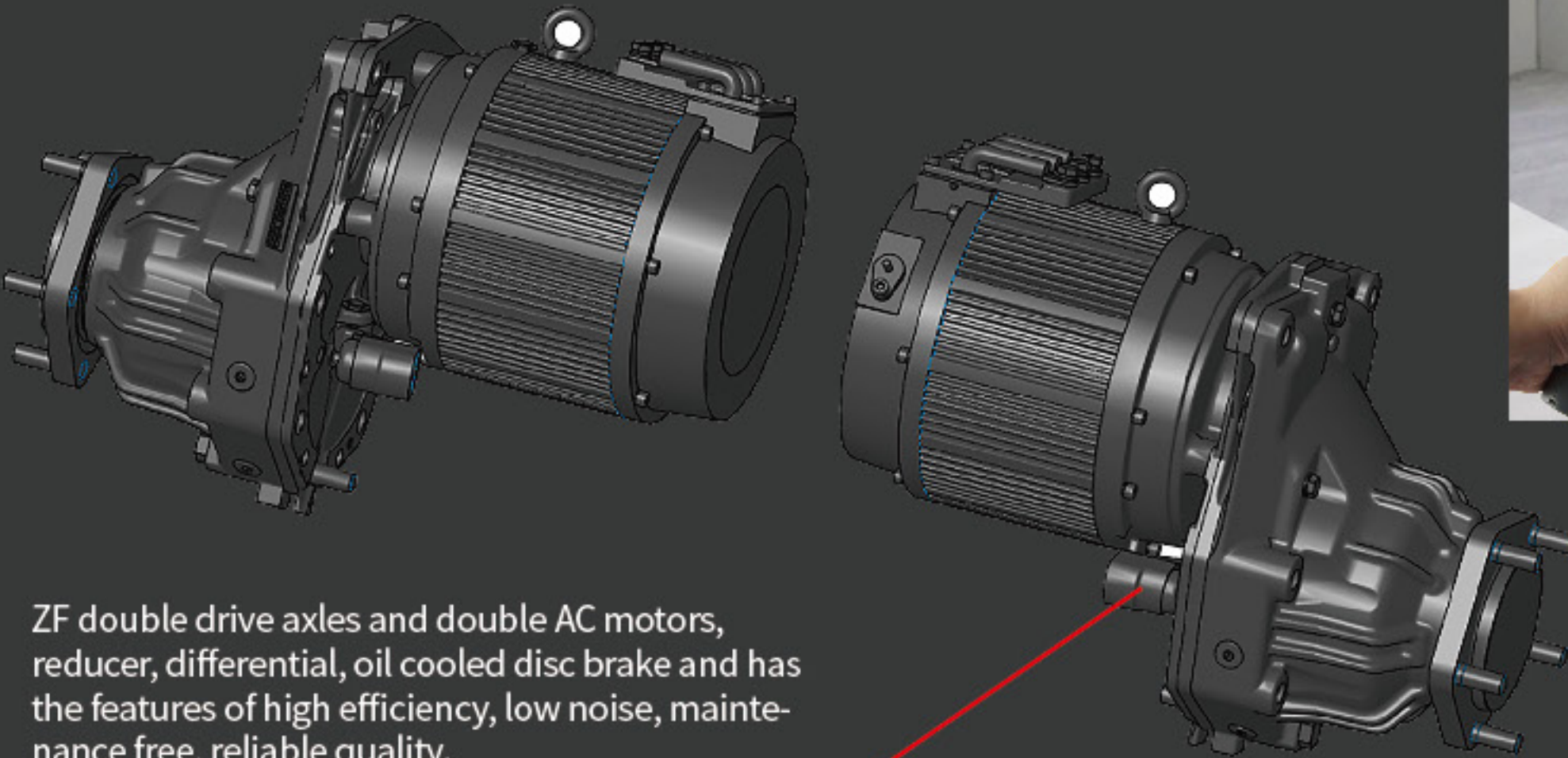

ZF double drive axles and double AC motors, reducer, differential, oil cooled disc brake and has the features of high efficiency, low noise, maintenance free, reliable quality.

HELI smart fleet management system (domestic basic edition)

Vehicle positioning

Statistical form

Remote diagnosis

Vehicle management

Remote monitoring

Identification recognition
 (optional)

Maintenance reminder

Weight management
 (optional)

Battery management

Collision management
 (optional)



Manufacturer and Technical Data						
Characteristics						
1.01	Manufacturer					HELI
1.02	Model			CPD15		CPD16
1.03	Configuration number			GE2DLI		GE2DLI
1.04	Rated capacity	Q	kg	1500		1600
1.05	Load center distance	c	mm			500
1.06	Power mode					Battery
1.07	Driving mode					Seated
1.08	Load distance, center of drive axle to fork	x	mm	367		367
1.09	Wheelbase	y	mm	1292		1292
Weight						
2.01	Total weight (with/without battery)		kg	2915/2635		3015/2735
2.02	Axle load (laden,front/rear)		kg	3895/520		4045/570
2.03	Axle load (unladen,front/rear)		kg	1365/1550		1385/1630
Tyres						
3.01	Tyre type					SE
3.02	Tyre size,front			18X7-8		18X7-8
3.03	Tyre size,rear			140/55-9		140/55-9
3.04	Wheels,number front/rear (x=driven wheels)			2x/2		2x/2
3.05	Tread, front	b ₁₀	mm	910		910
3.06	Tread, rear	b ₁₁	mm	890		890
Dimensions						
4.01	Mast tilt angle (forward/backward)	α/β	°	5/7		5/7
4.02	Height (mast lowered)	h ₁	mm	2175		2175
4.03	Free lifting height	h ₂	mm	90		90
4.04	Lifting height (standard)	h ₃	mm	3300		3300
4.05	Max. height,extended	h ₄	mm	4039		4039
4.06	Height of overhead guard	h ₆	mm	2040		2040
4.07	Height of seat	h ₇	mm	1047		1047
4.08	Towing coupling height	h ₁₀	mm	375		375
4.09	Overall length (with fork)	l ₁	mm	2925		2925
4.10	Overall length (without fork)	l ₂	mm	2005		2005
4.11	Overall width	b ₁	mm	1060/1076		1060/1076
4.12	Fork carriage,DIN standard			2A		2A
4.13	Fork size:thickness x width x length	s/e/l	mm	35/100/920		35/100/920
4.14	Distance between fork-arms, Max./Min.	b ₅	mm	960/200		960/200
4.15	Ground clearance (laden,between mast)	m ₁	mm	90		90
4.16	Ground clearance (laden,center of wheelbase)	m ₂	mm	100		100
4.17	Right angle stacker aisle width for pallet 1000 x1200mm crossways	A _{st}	mm	3315		3315
4.18	Right angle stacker aisle width for pallet 800 x1200mm lengthways	A _{st}	mm	3515		3515
4.19	Min. outside turning radius	W _a	mm	1745		1745
Performance Data						
5.01	Running speed		km/h	17/18		17/18
5.02	Lifting speed		m/s	0.46/0.65		0.46/0.65
5.03	Lowering speed (laden/unladen)		m/s	0.55/0.5		0.55/0.5
5.04	Max.drawbar pull (laden/unladen)		N	17500/11200		17500/11200
5.05	Max.gradeability (laden/unladen)		%	22/30		22/30
5.06	Acceleration time(10 m)(laden/unladen)		s	5.4/5		5.4/5
Battery						
6.01	Battery voltage/Capacity		V/Ah	80/202		80/202
6.02	Battery weight (Min./Max.)		kg	260/320		260/320
Motor and controller						
7.01	Driving motor powering (S2-60min)		kW	6X2		6X2
7.02	Lifting motor powering (S3-15%)		kW	17.6		17.6
7.03	Driving motor controlling mode					MOSFET/AC
7.04	Lifting motor controlling mode					MOSFET/AC
Addition data						
8.01	Service brake/Parking brake					Hydraulic/Hydraulic(automatic parking)
8.02	Operating pressure for attachments		Mpa	17.5		17.5

Note: Configuration 2: ZAPI; 3:INMOTION; 6: HELI Technology

CPD18	CPD20
GE2DLI	GE2DLI
1800	2000
367	372
1400	1400
3180/2900	3380/3100
4390/590	4700/680
1430/1750	1450/1930
200/50-10	200/50-10
16X6-8	16X6-8
2x/2	2x/2
920	920
910	910
5/7	5/7
2175	2175
90	90
3300	3300
4039	4039
2040	2040
1064	1064
375	375
3000	3000
2085	2085
1060/1120	1060/1120
2A	2A
35/100/920	40/122/920
960/200	960/200
90	90
100	100
3420	3420
3620	3620
1845	1845
17/18	17/18
0.42/0.6	0.42/0.6
0.55/0.5	0.55/0.5
18500/11500	18500/11500
22/30	22/30
5.4/5	5.4/5
80/202	80/202
260/320	260/320
6X2	6X2
17.6	17.6
17.5	17.5

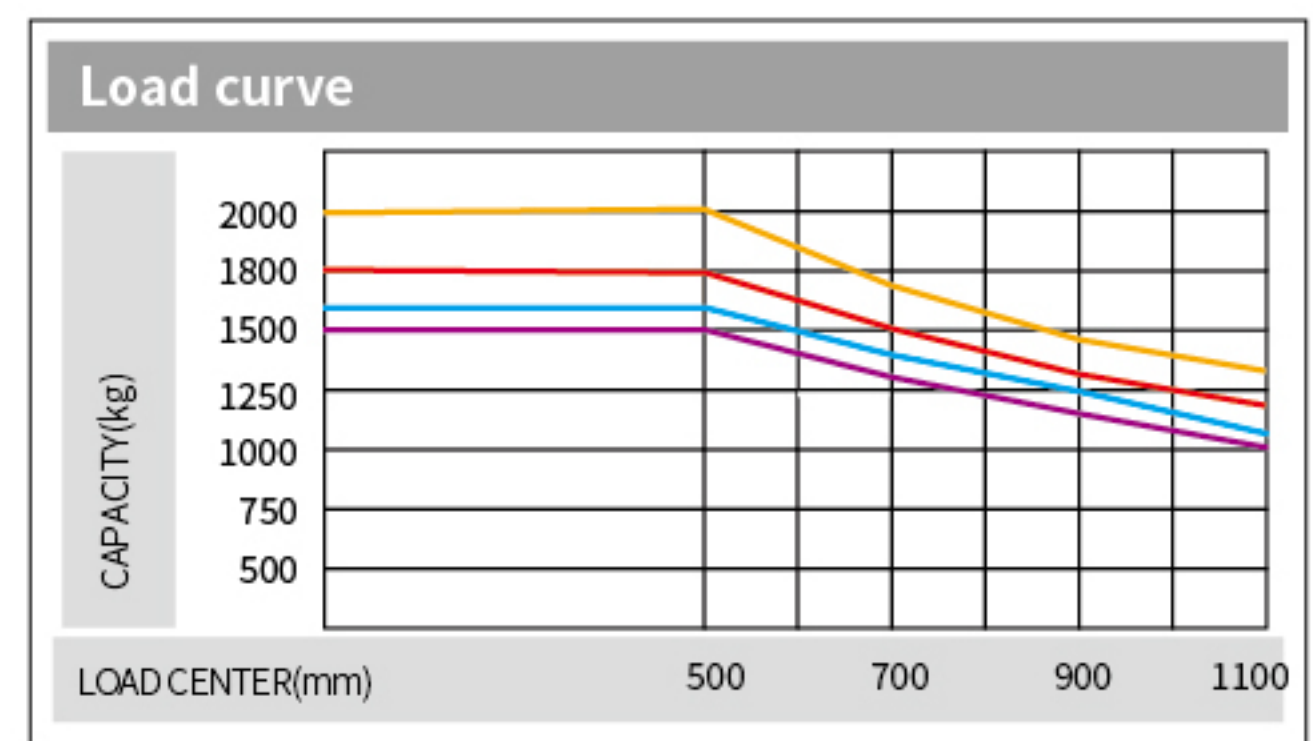
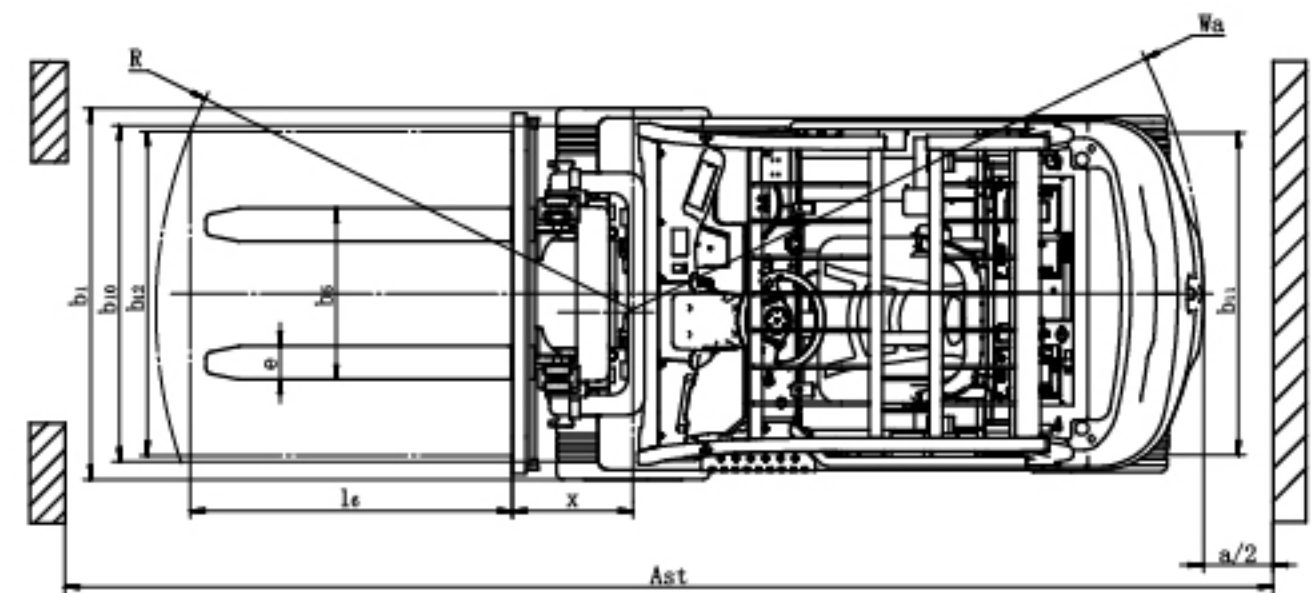
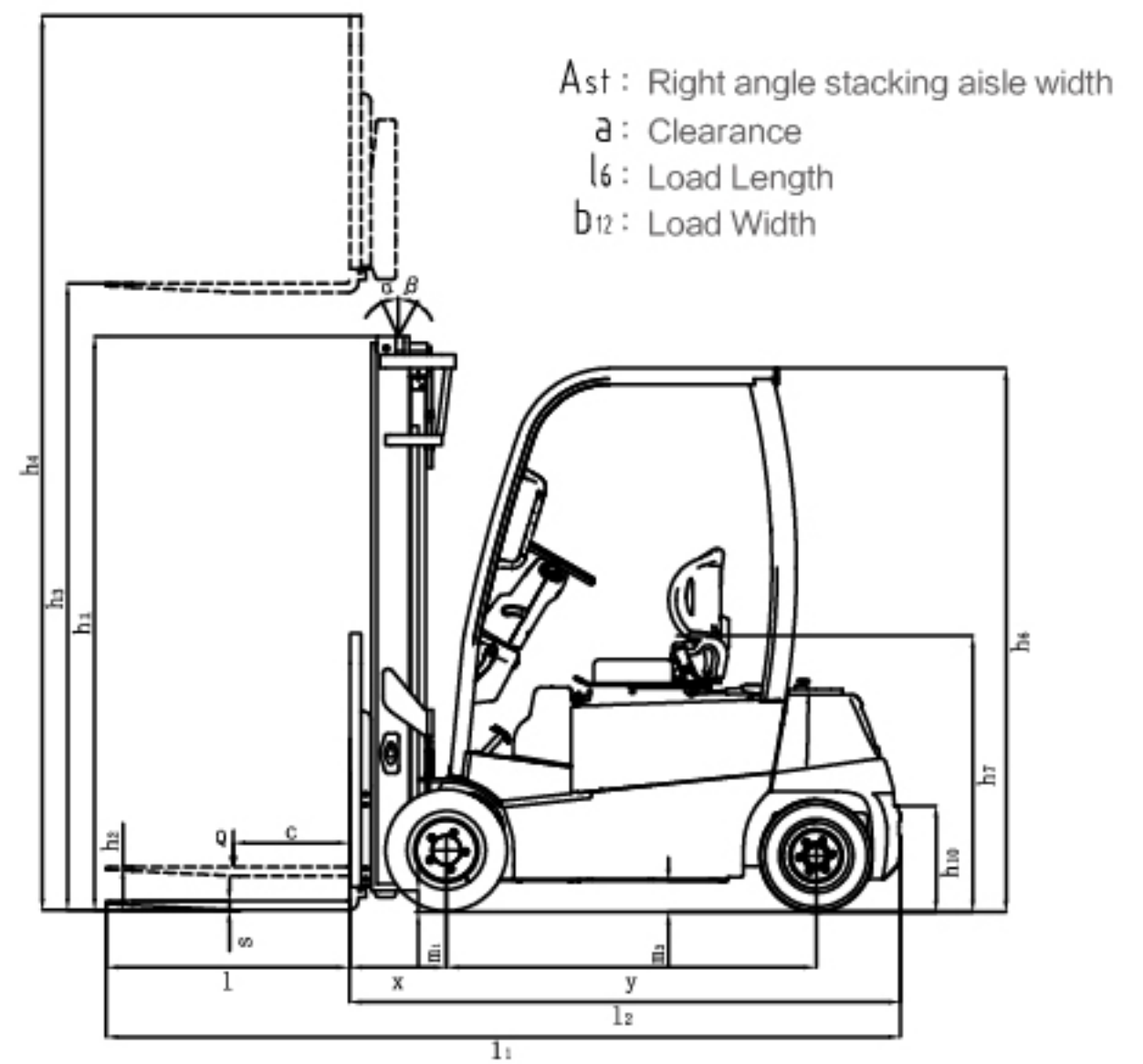

CPD15 CPD16 CPD18 CPD20

Note:The vertical axis stands for load capacity while the horizontal axis stands for load center which is calculated from the front surface of the forks to the gravity of the standard load. the standard load means a cubic with 1000mm edge length. When the mast is tilted forward, the worker using nonstandard forks for loading large goods, the load capacity will be reduced. The load capacity of standard mast at different load center can be known from this load chart.

WIDE VIEW MAST

mast model	Max lifting height mm	load capacity (load center 500mm)				mast overall height (fork to the ground)	service weight				mast tilting angle (°) α/β
		1.5t	1.6t	1.8t	2.0t		1.5-2t	1.5t	1.6t	1.8t	
M200	2000	1500	1600	1800	2000	1525	2843	2943	3099	3299	5-7
M250	2500	1500	1600	1800	2000	1775	2870	2970	3136	3336	5-7
M300	3000	1500	1600	1800	2000	2025	2899	2999	3164	3364	5-7
M330	3300	1500	1600	1800	2000	2175	2915	3015	3180	3380	5-7
M350	3500	1500	1600	1800	2000	2275	2926	3026	3191	3391	5-7
M370	3700	1500	1600	1800	2000	2375	2937	3037	3202	3402	5-7
M400	4000	1500	1600	1800	2000	2575	2980	3080	3245	3445	3-5
M425	4250	1500	1600	1800	2000	2700	3023	3123	3288	3488	3-5
M450	4500	1500	1600	1800	2000	2825	3038	3138	3303	3503	3-5
M500	5000	1250	1350	1600	1750	3075	3069	3169	3334	3534	3-5
M550	5500	1100	1250	1350	1500	3375	3127	3227	3392	3592	3-3
M600	6000	900	1000	1100	1300	3625	3158	3258	3423	3623	3-3

WIDE VIEW FULL FREE 2-STAGE MAST

mast model	Max lifting height mm	load capacity (load center 500mm)				mast overall height (fork to the ground)	free lifting height (with backrest)	service weight				mast tilting angle (°) α/β
		1.5t	1.6t	1.8t	2.0t			1.5-2t	1.5t	1.6t	1.8t	
ZM200	2000	1500	1600	1800	2000	1525	510	2870	2970	3135	3335	5-7
ZM250	2500	1500	1600	1800	2000	1775	760	2899	2999	3164	3364	5-7
ZM300	3000	1500	1600	1800	2000	2025	1010	2927	3027	3192	3392	5-7
ZM330	3300	1500	1600	1800	2000	2175	1160	2945	3045	3210	3410	5-7
ZM350	3500	1500	1600	1800	2000	2275	1260	2956	3056	3221	3421	5-7
ZM370	3700	1500	1600	1800	2000	2375	1360	2970	3070	3235	3435	5-7
ZM400	4000	1500	1600	1800	2000	2575	1560	3015	3115	3280	3480	3-5

WIDE VIEW FULL FREE 3-STAGE MAST

mast model	Max lifting height mm	load capacity (load center 500mm)				mast overall height (fork to the ground)	free lifting height (with backrest)	service weight				mast tilting angle (°) α/β
		1.5t	1.6t	1.8t	2.0t			1.5-2t	1.5t	1.6t	1.8t	
ZSM360	3600	1500	1600	1800	2000	1790	781	3059	3159	3324	3524	3-5
ZSM400	4000	1500	1600	1800	2000	1925	916	3084	3184	3349	3549	3-5
ZSM435	4350	1500	1600	1800	2000	2040	1031	3112	3212	3377	3577	3-5
ZSM450	4500	1500	1600	1800	2000	2090	1081	3123	3223	3388	3588	3-5
ZSM470	4700	1400	1500	1700	1900	2160	1151	3139	3239	3401	3601	3-5
ZSM480	4800	1350	1450	1650	1850	2190	1181	3144	3244	3406	3606	3-5
ZSM500	5000	1250	1350	1600	1750	2290	1281	3166	3266	3428	3628	3-5
ZSM540	5400	1100	1250	1350	1500	2425	1416	3222	3322	3484	3684	3-3
ZSM600	6000	900	1000	1100	1300	2640	1631	3262	3362	3524	3724	3-3
ZSM650	6500	800	900	1000	1200	2830	1821	3304	3404	3566	3766	3-3

LITHIUM BATTERY CHARGER

Lithium battery brand	HELI		CATL		EIKTO
Voltage/Capacity	80V/202	80V/271	80V/202	80V/271	80V/271
CPD15/16/18/20SQ	●	○	○	○	○
Low temperature heating of lithium battery	●				
Charger	D80V200ALi-123 D80V200ALi-423				

Note: ● standard ○ optional — non-configurable

Optional		
Security class	Steering automatic deceleration	●
	Reversing handle with horn button	●
	OPS system(Excluding descent)	●
	Complete OPS system	○
	Seat belt switch	●
	Multi way valve overload	●
	Fire extinguisher	○
	Backward buzzer	●
	Reversing Chinese language horn	○
	Electronic upper buffer	●
	Rearview mirror with angle in the middle	●
	Left and right rear mirror	○
	Tilt speed limit	●
	Active stabilization(Lifting height 4m and above)	●
Comfort class	Standard seat	●
	Fully suspended seat	○
	USB power	●
	Mechanical valve	●
	Solenoid valve (proportional valve + thumb switch)	-
	Fan	○
	Color screen instrument	●
	Heater	
	Performance mode control	●
	Steering wheel with operation ball	●
Steering wheel without operation ball	○	
Non standard overhead guard	The height of overhead guard is increased by 50mm	○
	Overhead guard with protective net	○
Cab/windshield glass	Cab	○
	Fit the front windshield	○
	Equipped with rear windshield	○
	Equipped with top rain glass	○
Light class	No rear work lights or rear blue lights	●
	LED rear work light	○
	LED rear blue light (without switch control)	○
	led rear work light and led rear blue light (without switch control)	○
	LED flickering warning light	●
	LED rotary warning light	○
Other	Led rotary buzzer warning light	○
	HEDING lithium battery	●
	ENEROC lithium battery	○
	EIKTO lithium battery	○
	Solid tire	●
	Traceless tyre	○
	Single tire (front wheel)	●
	Double tire (front wheel)	-
	Metric thread	●
	American thread	○
	Sleeve for Tilting cylinder	○
	Tilting cylinder,sleeve for steering cylinder	○
	HELI package	●
	Neutral package	○
	Chinese sticker	●
	English sticker	○
	Custom-made sticker	○
HELI smart fleet management system(standard version)	○	

Note: ● standard ○ optional — non-configurable



检测 CNAS L7096

HELI CANADA

5705, place Kubota
Drummondville (Qc)
Canada, J2B 6V4
1-833-HELICAN
info@heliforklift.ca
heliforklift.ca



Our products are subject to improvements and changes without notice.