



3500lbs (1600 kg) Electric 24V Pallet Stacker CTD16-960H



High efficiency hydraulic pump delivers power and performance

Rugged structure and cover is designed for durability

Electronic power steer system is responsive and quiet

CTD16-960H has multiple safety features including automatic deceleration in turns

Emergency reverse switch and emergency brakes help ensure safe operation

Small turning radius make the CTD16-960H easy to use in narrow aisles

AC drive motor is powerful and maintenance free

Steel grid finger guard comes standard on all units

Side operating stance makes truck highly maneuverable and gives operator a broader view

Handle integrates keyswitch and meter to make operation easy and convenient

Unit comes standard with Curtis controls, which incorporate multiple, automatic protection

The lifting / lowering system has been greatly improved with three speed lowering mode, automatic lift limiting and high lift speed automatic adjustment



Two-way magnetic valve, three drop speed mode;

Automatic lifting limit, proximity switch, long life;

CTD16-960H 3500lbs (1600 kg)



Manufacturer's Data and Design Characteristics

Characteristics

1.1	Manufacturer					HELI			
1.2	Model					CTD16-960H			
1.3	Operator type					Walkie			
1.4	Rated Capacity	Q	lb	kg	3500		1600		
1.5	Mast Type					Full free 3-stage			
1.6	Load center	c	in	mm	23.6		600		
1.7	Wheelbase	y	in	mm	45.9		1330		
1.8	Distance - axle centerline to fork face	x	in	mm	28.3		697		

Wheels

2.1	Tire type					Polyurethane			
2.2	Wheel - number drive, balance, load					1/2/4			

Dimensions

3.1	Lift Height	h3	in	mm	145.7	3700	153.5	3900	165.4	4200	177.2	4500	185.0	4700	196.8	5000
3.2	Mast height - extended	h1	in	mm	165.4	4200	173.2	4400	185.0	4700	196.8	5000	204.7	5200	216.5	5500
3.3	Mast height - lowered	h4	in	mm	70.9	1800	74.8	1900	78.1	1985	82.1	2085	84.1	2135	88.0	2235
3.4	Fork height - lowered	h13	in	mm	2.2				55							
3.5	Fork dimensions	s/e/L	in	mm	1.6 / 3.9 / 42.1				40 / 100 / 1070							
3.6	Overall length	L1	in	mm	75.2				1910							
3.7	Overall width - chassis	b1	in	mm	31.5				800							
3.8	Min. turning radius	Wa	in	mm	59.1				1500							
3.9	Aisle with 40" x 48" (1000x1200) pallet		in	mm	79.9				2030							
3.10	Aisle with 32" x 48" (800x1200) pallet		in	mm	72.8				1850							
3.11	Min. ground clearance	m2	in	mm	2.0				50							
3.12	Outrigger width - outside	b2	in	mm	57.9				1470							

Performance

4.1	Travel speed (with / without load)	mph	km/h	3.1 / 3.4		5.0 / 5.5		
4.2	Lift speed (with / without load)	in/s	mm/s	5.1 / 7.5		130 / 180		
4.3	Lower speed (with / without load)	in/s	mm/s	3.9 / 7.5		100 / 180		
4.4	Max. gradeability (with / without load)			%		5 / 7		

Electrical

5.1	Drive motor type / rating	hp	kW	AC / 2.0		AC / 1.5		
5.2	Lift motor type / rating	hp	kW	DC / 4.0		DC / 3.0		
5.3	Steer motor type / rating	hp	kW	DC / 0.2		DC / 0.15		
5.4	Service brake type					Electromagnetic / Regenerative		
5.5	Controller					Curtis		
5.6	Battery voltage / rated capacity			V/Ah		24 / 270		

Weight

6.1	Battery weight (±5%)	lb	kg	540		245		
6.2	Service weight (with 63" [1600mm] mast)	lb	kg	3330		1510		

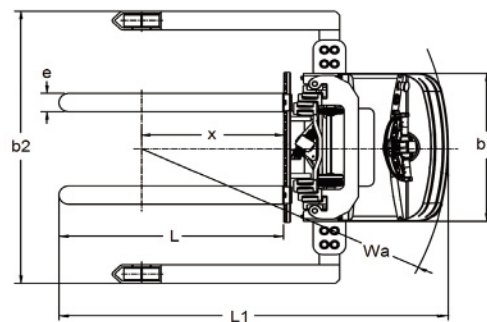
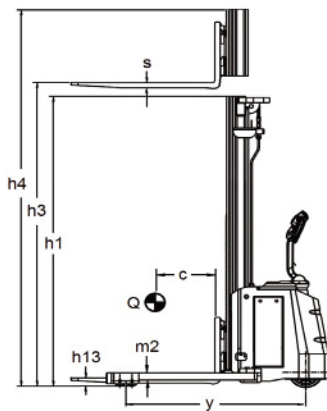

检测 CNAS L7096

HELI CANADA

5705, place Kubota
Drummondville (Qc)
Canada, J2B 6V4
1-833-HELICAN
info@heliforklift.ca
heliforklift.ca

