

CTD10-090
1.0 Ton Electric Stacker
Lifting Height: 1600-1950mm

Load Curve

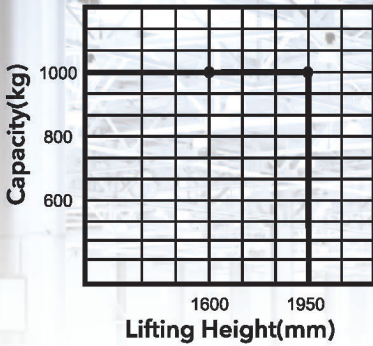

Advantages

Configuration and Performance

- Separately excited motor, Strong climbing ability.
- High strength forks.
- Built-in charger is standard.
- Automatic lifting limit, Motor and battery life extension.

Safety

- Stepless speed control system, safe and quiet.
- Controller with Multiple automatic protection
- Emergency reversing device/Emergency brake switch.

Straddle



Built-in charger

Free-maintained battery

Adjustable forks at three choices

Type	Lift height (mm)	Mast type	Outside width between legs (mm)	Inside width between legs (mm)
CTD10-090	1600/1950	SINGLE STAGE	1120/1270/1420	970/1120/1270

HELI CTD10-090

Feature		
Model		CTD10
Configuration No.		090
Type		Straddle
Mast type		Single stage
Load capacity	kg	1000
Load center	mm	600
Wheel base	mm	1134
Operating type		Walkie
Wheels		
Wheels type		PU
Wheel quantity Driving wheel/Balance wheel/Bearing wheel		1/1/4
Dimension		
Standard lift height	mm	1600/1950
Max.extend height	mm	2055/2405
Mast lowered height	mm	2055/2405
Lowered fork height	mm	55
Fork size(length/width/thickness)	mm	1070/100/40
Overall length	mm	1640
Overall width	mm	940
Outside width between forks	mm	200-812
Inside width between forks	mm	0-612
Min.Turning radius	mm	1344
Min.Aisle width for pallets 800×1200	mm	1894
Min.Aisle width for pallets 1000×1200	mm	1936
Min.ground clearance	mm	50
Performance		
Travel speed,laden/unladed	km/h	3/3.5
Lift speed,laden/unladed	mm/s	120/180
Lowering speed,laden/unladed	mm/s	120/120
Gradeability,laden/unladed	%	5/7
Electrical configuration		
Drive motor/Lift motor/Steering motor	kW	DC0.63/DC2.0
Battery voltage	V	24
Battery capacity	Ah	85
Brake		Electromagnetic/Regenerative
Controller		HELI(Options CURTIS)
Weight		
Battery weight	kg	48
Service weight with battery	kg	514

* Details of specifications and equipment are based on information available at time of printing and may change without notice.

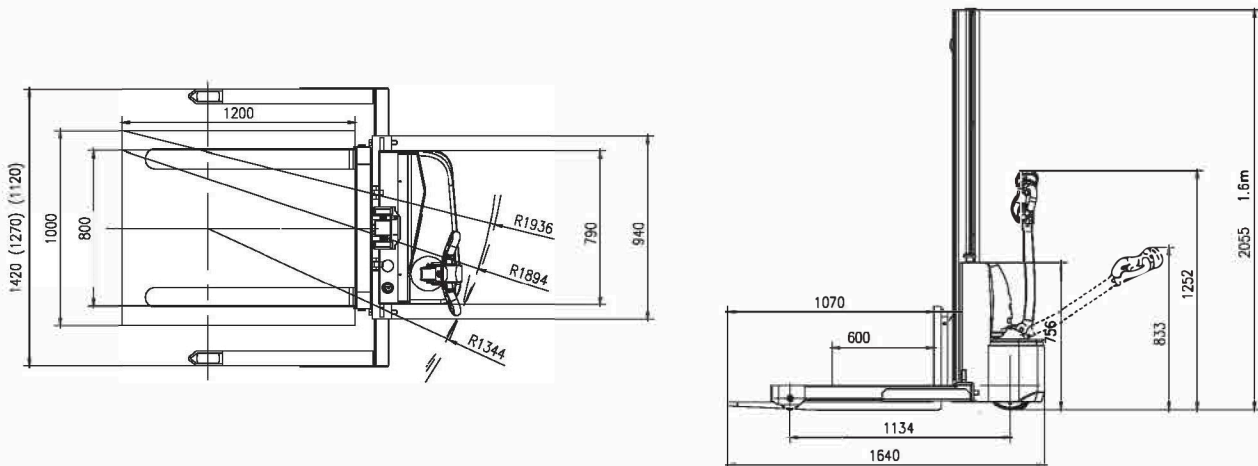

检测 CNAS L7096

HELI CANADA

5705, place Kubota
Drummondville (Qc)
Canada, J2B 6V4
1-833-HELICAN
info@heliforklift.ca
heliforklift.ca



Our products are subject to improvements and changes without notice.