

**CTD10-050**  
**1.0 Ton**  
**Electric Straddle Stacker**  
Lifting Height: 2000-3300mm

**Load Curve**

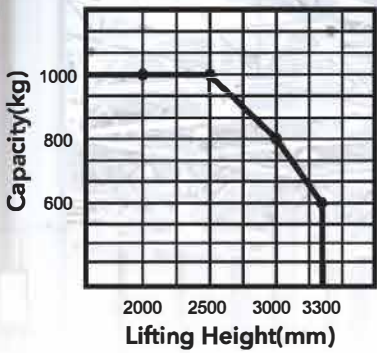

**Advantages**

**Configuration and Performance**

- ⊙ Separately excited motor, Strong climbing ability.
- ⊙ High strength forks.
- ⊙ Built-in charger.
- ⊙ Automatic lifting limit, Motor and battery life extension.

**Safety**

- ⊙ Stepless speed control system, safe and quiet.
- ⊙ Controller with Multiple automatic protection
- ⊙ Emergency reversing device/Emergency brake switch.

**Built-in charger**

**Free-maintained battery**

**Adjustable forks at three choices**

Type	Lift height (mm)	Mast type	Outside width between legs (mm)	Inside width between legs (mm)
CTD10-050	2000/2500/3000/3300	Standard 2-STAGE	1120/1270/1420	970/1120/1270

# HELI CTD10-050

Feature		
Model		CTD10-050
Type		Straddle
Mast type		Standard 2-Stage
Load capacity	kg	1000
Load center	mm	600
Wheel base	mm	1204
Operating type		Walkie
Wheels		
Wheels type		PU
Wheel quantity Driving wheel/Balance wheel/Bearing wheel		1/1/2
Dimension		
Standard lift height	mm	2000/2500/3000/3300
Max.extend height	mm	2593/3093/3593/3893
Mast lowered height	mm	1620/1870/2120/2270
Lowered fork height	mm	55
Fork size(length/width/thickness)	mm	1070/100/40
Overall length	mm	1721
Overall width	mm	940
Outside width between forks	mm	200-812
Inside width between forks	mm	0-612
Min.Turning radius	mm	1411
Min.Aisle width for pallets 800×1200	mm	1970
Min.Aisle width for pallets 1000×1200	mm	2010
Min.ground clearance	mm	50
Performance		
Travel speed,laden/unladed	km/h	3/3.5
Lift speed,laden/unladed	mm/s	120/180
Lowering speed,laden/unladed	mm/s	120/120
Gradeability,laden/unladed	%	5/7
Electrical configuration		
Drive motor/Lift motor/Steering motor	kW	DC0.63/DC2.0
Battery voltage	V	24
Battery capacity	Ah	85
Brake		Electromagnetic/Regenerative
Controller		HELI(Options CURTIS)
Weight		
Battery weight	kg	48
Service weight with battery	kg	710

\* Details of specifications and equipment are based on information available at time of printing and may change without notice.

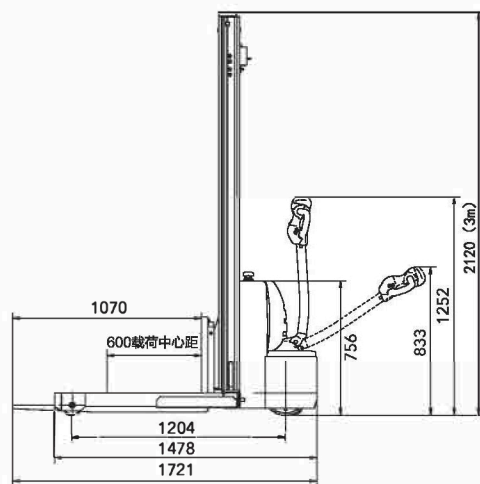
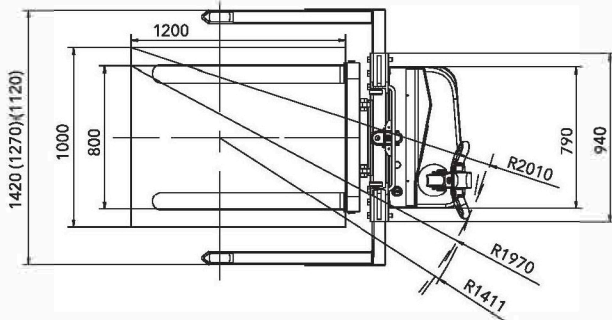

## HELI CANADA

5705, place Kubota  
Drummondville (Qc)  
Canada, J2B 6V4  
1-833-HELICAN  
info@heliforklift.ca  
heliforklift.ca



Our products are subject to improvements and changes without notice.