

CQDH14-850

1.4Ton Scissor Stacker

Load Curve

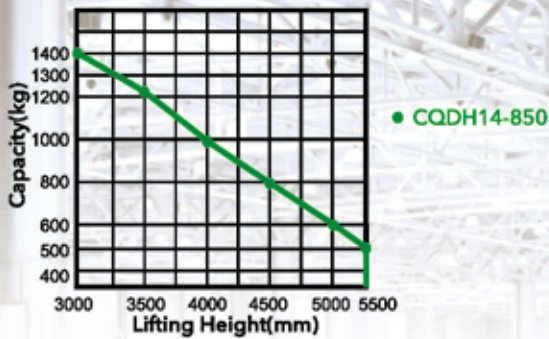

Advantages

Configuration and Performance

- Electronic power steering system, light and low noise.
- Two-way magnetic valve, three drop speed mode.
- AC Driving system, No carbon brush, maintenance free.
- Electromagnetic, regenerative braking system.
- Lifting, reach, regenerative limit, motor and battery life extension.
- Equipped with double oil cylinder, fork tilt more smoothly.
- Standard moon walk. Handle at any angle, the vehicle goes straight.

Safety

- Curve automatic deceleration devices, more safe.
- Stepless speed control system, safe and quiet.
- Controller with Multiple automatic protection.
- Emergency reversing device/Emergency brake switch.
- High position automatic reduction device.



AC | EPS | Moon Walk

Down mode at 3 speeds

Type	Lift height (mm)	Outside width between forks (mm)	Inside width between forks (mm)
CQDH14-850	3500/3800/4000/4200/4500/5000/5500	1270/1420/1470	1070/1220/1270

HELI CQDH14-850

Feature		
Model		CQDH14-850
Type		Reach(Tilt,Side shifter)
Mast type		Standard 3-Stage
Load capacity	kg	1400
Load center	mm	500
Wheel base	mm	1478
Operating type		Walkie
Wheels		
Wheels type		PU
Wheel quantity Driving wheel/ Balance wheel/Bearing wheel		1/0/4
Dimension		
Reach distance	mm	0-550
Standard lift height	mm	3500/3800/4000/4500/5000/5500
Max.extend height	mm	4710/5010/5210/5710/6210/6720
Mast lowered height	mm	1914/2014/2081/2248/2415/2582
Lowered fork height	mm	55
Fork size(length/width/thickness)	mm	1070/100/40
Overall length	mm	2225
Overall width	mm	1430
Outside width between forks	mm	200-812
Distance shift fork side	mm	150
Tilt of fork(F/B)	mm	4/3
Min.Turning radius		1566
Min.Aisle width for pallets 800×1200	km/h	2135
Min.Aisle width for pallets 1000×1200	mm/s	2315
Min.ground clearance	mm/s	30
Performance		
Travel speed,laden/unladen		3.5/4
Lift speed,laden/unladen	kW	130/150
Lowering speed,laden/unladen	V	100/180
Gradeability,laden/unladen	Ah	3/5
Electrical configuration		
Drive motor/Lift motor/Steering motor		AC1.5/DC4.5/DC0.15
Battery voltage		24
Battery capacity	kg	345 (Options:FAAM345)
Brake	kg	Electromagnetic/Regenerative
Controller		ZAPI (Option CURTIS)
Weight		
Battery weight		298
Service weight with battery		2296

* Details of specifications and equipment are based on information available at time of printing and may change without notice.

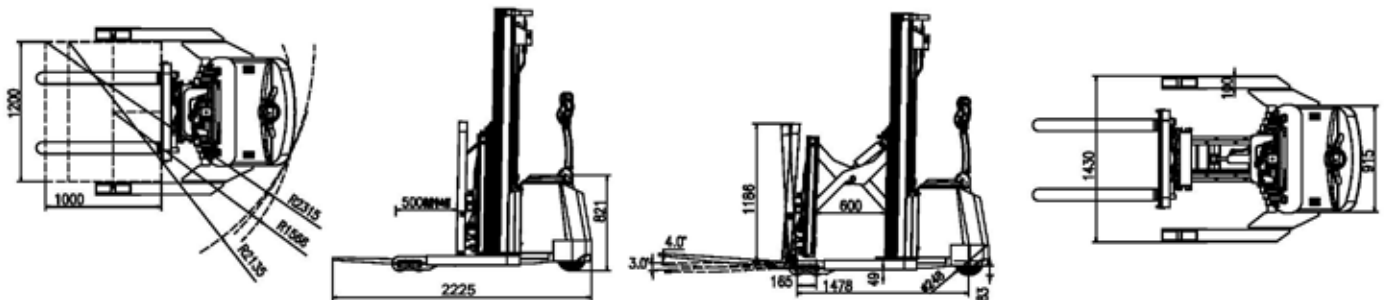

检测 CNAS L7096

HELI CANADA

5705, place Kubota
Drummondville (Qc)
Canada, J2B 6V4
1-833-HELICAN
info@heliforklift.ca
heliforklift.ca



Our products are subject to improvements and changes without notice.